

SONY®

Digital BETACAM



Digital Betacam Camcorder

DVW-970

DVW-970P

A New Digital Betacam™ Camcorder – Enhancing Your Creativity with Exceptional Picture Quality and Versatility

Since its introduction in 1993, the Sony Digital Betacam Series has been accepted as the mainstream workhorse for standard-definition video productions. For the past decade, first- and second-generation Digital Betacam camcorders, the DVW-700 and DVW-790WS Series, have consistently served numerous top-quality SD video productions – from documentaries and dramas to TV commercials – with the outstanding performance and reliability that only the Digital Betacam format can provide.

Recognizing the ever-changing demands of today's and tomorrow's production environments, Sony now evolves its Digital Betacam product line with the introduction of the DVW-970* camcorder. Inheriting the market-proven features of previous models, the DVW-970 combines the latest camera technology, with enhanced reliability, mobility, and operability.

At the center of its picture performance are field-proven Power HAD™ EX CCDs combined with highly precise 14-bit A/D conversion quality. These technologies deliver in the DVW-970 excellent sensitivity, reduced noise, and smear characteristics, as well as progressive scanning mode, which includes 24P for film-like shooting. A variety of unique features such as slow shutter, interval recording, and picture cache recording, have also been incorporated. Furthermore, use of the latest mechanics results in reduced size and power consumption and lower acoustic noise, for much greater mobility and reliability.

With its superb performance and a range of sophisticated features, the DVW-970 Digital Betacam Camcorder is a worthy successor and the leading solution for broadcasters who want top-quality SD productions.

* In this brochure, the DVW-970 refers to both DVW-970 for NTSC and DVW-970P for PAL.



INNOVATIVE PERFORMANCE ACCELERATING IMAGINATION



Power HAD EX CCD

The DVW-970 camcorder is equipped with proven state-of-the-art three-chip 2/3-inch type Sony Power HAD EX CCDs. This CCD imager achieves a high sensitivity of F11, an excellent signal-to-noise ratio of 65 dB (NTSC)/63 dB (PAL) and a remarkably low smear level of -145 dB (typical) allowing the DVW-970 to produce pictures of stunning quality. Integration of the Power HAD EX CCDs also allows progressive scanning, including 24P* for film-like effects.

* For DVW-970 (NTSC model) only. An optional CBK-FC01 Pull-down board required.

14-bit A/D Conversion

The DVW-970 incorporates a high-integrity 14-bit A/D conversion circuit so that images captured by the Power HAD EX CCDs are processed with great precision. This high-resolution A/D conversion allows the contrast to be reproduced faithfully in both mid-to-dark tone and bright areas of the picture.

Advanced Digital Signal Processing (ADSP)

A key to quality in DSP cameras is how many bits are used in their nonlinear process, such as gamma correction. The ADSP of the DVW-970 camcorder uses more than 30 bits in its nonlinear process, minimizing round-off errors to maintain the high quality of the Power HAD EX CCDs. The ADSP also enables highly sophisticated image controls, such as the multi-matrix function, triple skin-tone detail control, and adaptive highlight control.

Outstanding Picture Quality of Digital Betacam Recording

The DVW-970 records a 4:2:2 component digital video signal, which provides superb picture quality, multi-generation capabilities, and excellent editing performance. The use of a very mild intra-field compression ratio of about 2:1 produces picture quality that is equivalent to base-band signals.

High-quality Digital Audio

The DVW-970 also provides four-channels of 20-bit/48 kHz digital audio. You can freely select the audio input signal for each channel, choosing from front microphone and additional wired or wireless microphones.

Long Recording Time

The DVW-970 camcorder's long recording and playback times enable recordings of up to 40 minutes on a small cassette.



OPERATIONAL VERSATILITY

Compact, Lightweight, and Low Power Consumption

The DVW-970 is designed to be very compact and lightweight, for a high level of mobility in the field. It weighs approximately 5.4 kg (11 lb 14 oz) including the viewfinder, microphone, BCT-D40 tape, and BP-GL95 Battery Pack. With its new-generation LSI, the camcorder achieves a low power consumption of approximately 29 W.

Stereo Audio Output

A stereo audio line output is available from the 5-pin XLR connector on the rear of the DVW-970 camcorder. This provides two analog audio output channels, which are selectable between either Channel-1/2 or Channel-3/4.

Camera Remote Control

Camera settings and basic VTR functions can be remotely controlled using an optional RM-B150 or RM-B750 Remote Control Unit via its 8-pin remote connector.



Dual Optical Filters Plus Electric Color Correction

The DVW-970 comes equipped with dual optical filters for Color Correction (CC) and Neutral Density (ND) for flexible color and exposure control. In addition, it is equipped with an electronic Color Correction function, which gives operators the choice of correcting color temperature optically or electronically, according to their needs.



User-friendly Menu Controls

The DVW-970 offers an easy-to-use menu system to facilitate detailed camera settings. Setup parameters are well organized in a two-layer menu system: a user menu and sub menu. The user menu allows access only to the standard setup functions needed by the camera operator, and can be customized for fast access to the menus they use frequently. The sub menu makes all menus accessible, each of which is categorized into groups such as paint, file, and maintenance. Menu pages can be displayed in the camcorder viewfinder, as well as on a monitor screen via the video test output, and the menu control system can be operated easily using a rotary switch on the camcorder.

Rugged and Ergonomic Design

The design of the DVW-970 is based on years of Sony experience in camera ergonomics, and provides high mobility and balance. All switches, meters, and indicators are in the most logical places and are positioned for optimum functionality and ease of use. Operators will immediately feel at home with the DVW-970, which takes user comfort to new levels.

Versatile Interfaces

The DVW-970 provides an analog composite output as standard, with an SDI output board (the CBK-SD01) available as a plug-in option. The CBK-SD01 optional board can be installed within the camcorder chassis to eliminate the need for an external camera adaptor unit, maintaining the compactness and balance of the camcorder.

Battery-remaining Display on Viewfinder

With a Sony Professional Info Battery, the remaining capacity is automatically detected and transmitted to the DVW-970 camcorder. The remaining capacity is indicated in the camcorder viewfinder in 10% steps.



Intelligent Light System

An optional portable light (maximum 50 W) can be attached to the camcorder, using a standard lighting connector and specially designed short cable for operation from the camcorder battery. The light can be switched on and off manually, or automatically synchronized with the camcorder's REC start function.



Slot for WRR-855 Series Wireless Microphone Receiver

An optional Sony wireless microphone receiver, the WRR-855A/855B, slots directly into the camcorder body without requiring a cable connection. This maintains camcorder balance and keeps the body compact, avoiding any loss of mobility.



Assignable Functions

Functions frequently used in the field can be assigned to a push button and a simple slide switch, allowing the operator to make rapid changes when working in the field.

The following functions can be assigned:

- Push button: disable, picture cache on/off, test out character on/off, VF marker on/off, re-take, ATW on/off, return video, lens return, recording start/stop, turbo gain on/off, zebra on/off, D5600 on/off
- Slide switch: disable, picture cache on/off, test out character on/off, marker on/off, zebra on/off, D5600 on/off

Turbo Gain

The Turbo Gain function boosts the gain level up to +48 dB at the touch of a button. This makes it possible to shoot in extremely low-light conditions. The gain level of the Turbo Function is selectable.

Adjustable Shoulder Pad

The position of the shoulder pad on the DVW-970 can be adjusted either forwards or backwards without using a screwdriver to provide operators with a comfortable and well-balanced camera.



Memory Stick™ System Stores Camera Setup Parameters

The DVW-970 incorporates the Sony Memory Stick system for the storage and recall of setup parameters. This is an easy, effective system for storing and recalling camera parameters for individual scenes, plus individual operators' camera-setup preferences including assignable button settings.



The Memory Stick media is an optional accessory.

CREATIVE VERSATILITY

Film-like Images with Progressive Mode

Incorporating Sony Power HAD EX CCDs, the DVW-970 (NTSC model) and DVW-970P (PAL model) generate progressive images of 29.97P and 25P respectively, delivering outstanding clarity as well as a cinematic look. In addition, the DVW-970 (NTSC model) can produce 24P images when an optional CBK-FC01 Pull-down Board is installed, offering film-like motion effects. Images captured in 24P scanning mode in the camera head are 2-3 pull-downed and recorded on tape at 59.94i field rate.

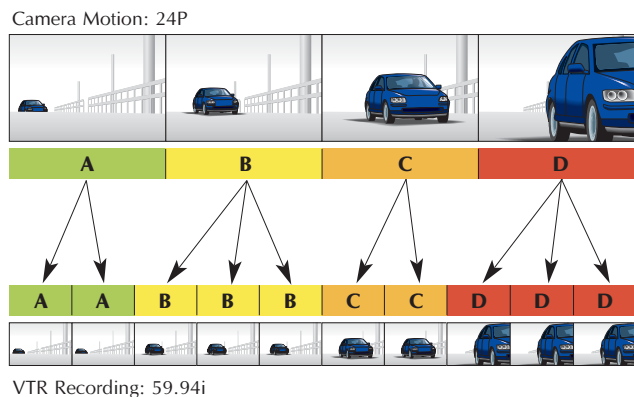

Low-light Shooting

The DVW-970 offers two convenient functions for capturing clear images in low-light environments – a slow shutter mode and Turbo Gain function. The slow shutter mode allows the charge-accumulation period of the CCD to be extended to 16 frames, not only increasing the sensitivity but also producing a blurring effect. The Turbo Gain function enables the camera gain to be boosted up to +48 dB. The slow shutter can be used either alone or together with an electric gain-up function depending on the shooting situation or the operator's preferences.

Picture Cache Recording*

Picture Cache Recording is a convenient function whereby up to eight seconds of video signal are buffered into memory before the REC button is even pressed. This means that everything that happened eight seconds before the REC button was pressed, in Standby mode, will still be recorded to tape – a capability that can help prevent the loss of unexpected but important events occurring before the operator even has the chance to press the REC button.

* An optional CBK-MB01 Picture Cache Board required.

Interval Recording*

Interval Recording is a useful function that intermittently records signals at pre-determined intervals (automatic and manual), ideal for recording over long periods. In manual mode, a specified number of frames is recorded every time the REC button is pressed or the camcorder repeatedly records at a specified interval after the REC button is pressed. In auto mode, the camera records frames at pre-determined intervals over a pre-determined total shooting time. The Interval Recording function allows recordings to be made over long time periods on a single tape, and minimizes wear of the tape-drive mechanism.

* An optional CBK-MB01 Picture Cache Board required.

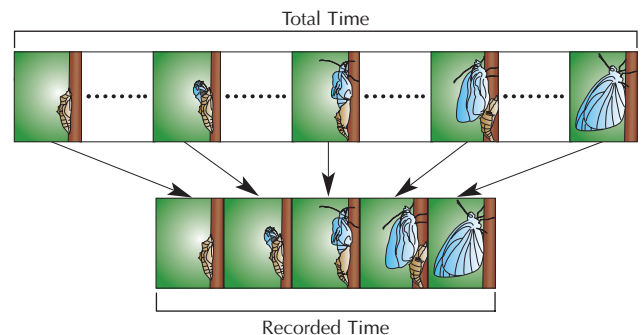

Selectable Gamma Table Including Film-like Gamma

A selectable gamma table is provided to easily give a specific look to a picture by selecting from multiple fixed gamma patterns including so-called film-like gamma. Five patterns of film-like gamma and six patterns of standard gamma can be selected.

TruEye™ Processor

The Sony TruEye processor is one of the most innovative features of Sony digital signal processing technology. This technology makes it possible to virtually eliminate hue distortion, particularly obvious in high light conditions that result from conventional RGB analog or digital processing. By processing the video signal data at three levels – brightness, hue, and saturation – similar to how the human eye works, the TruEye feature assists in the reproduction of natural skin tones.

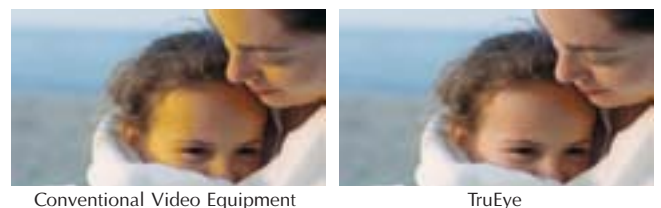

Adaptive Highlight Control

The DVW-970 camcorder provides multiple knee-points/slopes for superior overexposure control. The camcorder analyzes the highlight areas of a scene and automatically sets and optimizes multiple knee points/slopes accordingly. This enables the reproduction of extremely difficult images (such as an interior scene that includes a brightly sunlit window) with much more overexposure latitude. This function applies only to input video levels in excess of the knee point; the middle- and low-luminance parts of the video signal are unaffected by this control.

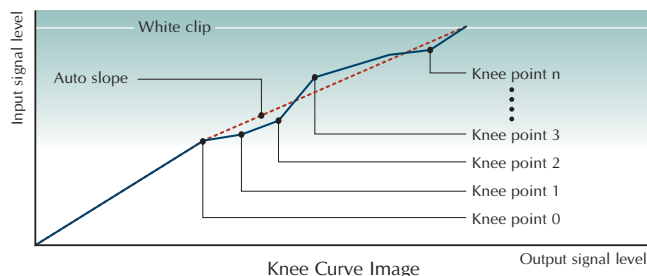
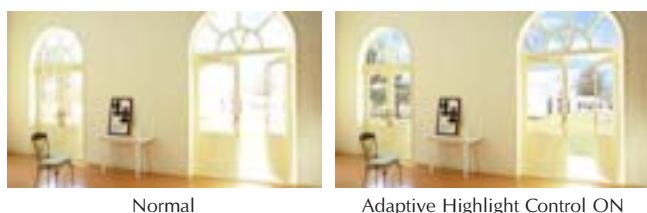

Triple Skin Tone Detail Control

The DVW-970 comes equipped with a Triple Skin Tone Detail control function, which allows for independent detail control over three specified colors. This enhances the capability of Skin Tone Detail correction - enabling one color selection to be used for reducing the detail level of skin color, and two other selections to be used for either increasing or decreasing the detail level of two other objects.

Variable Black Gamma Range

The Variable Black Gamma Range function allows for fine adjustment of tonal reproduction in the shadow area. This feature can help to bring out details from the dark parts of the picture without affecting mid-tones while maintaining the absolute black level. The variable range is LOW, Low MID, High MID, and HIGH.

Auto-tracing White Balance (ATW)

The DVW-970 offers an Auto-tracing White Balance function that automatically adjusts the camera's color temperature in real time with a change of the lighting. This is especially useful when a shoot is performed across different environments, such as from indoors to outdoors.

Multi-matrix Function

The Multi-matrix function enables color adjustments to be applied over a color and/or hue range as specified by the operator. The color spectrum is divided into 16 areas of adjustment, where the hue and/or saturation of each area can be adjusted. This provides interesting in-camera color effects – similar to secondary color correction.



Electronic Soft Focus

The Electronic Soft Focus included in the camcorder applies an effect similar to using an optical soft-focus filter – but in a much more convenient way. Electronic Soft Focus uses the detail signal to reduce, rather than increase, the sharpness of the picture. By subtracting the detail signal from the original signal (as opposed to adding it as in conventional image enhancement), Electronic Soft Focus is able to provide a picture that is “softer” than that achieved when detail is switched off completely.

Electronic Soft Focus can be used in conjunction with Skin-tone Detail to change only the sharpness within a specific color or hue range.

Color Temperature Control

It is possible to dial in the required color temperature of the camera. The overall color balance of the picture can be changed to make it warmer or cooler. This feature can be used very creatively, particularly in scenes with mixed color lighting.

FLEXIBLE METADATA RECORDING

The DVW-970 is capable of recording a variety of metadata, a huge advantage that delivers a dramatic increase in productivity when searching for data in subsequent production processes.

Essence Mark™ Handling

Essence Marks can be set during the shoot either manually or automatically. Each time the 'return' button on the lens is pressed, an Essence Mark is set. When a tape containing Essence Marks is played back on a DVW-2000 Series VTR, the Essence Mark positions are automatically detected and a list of all marks is generated for display on a video monitor. This allows operators to quickly select and cue-up to the scenes of interest.

UMID*¹ Recording

The DVW-970 is also capable of recording a UMID (Unique Material Identifier) which consists of a globally unique number or a material number. The UMID is automatically generated and recorded on tape at every scene change, proving invaluable when searching for required scenes in subsequent reviewing and editing processes. Sony supports UMID as well as Extended UMID*² for further operational convenience.

*1 UMID is recognized as standard under SMPTE 330M.

*2 Extended UMID adds signature meta-data, time, positioning, and user information to the Basic UMID.

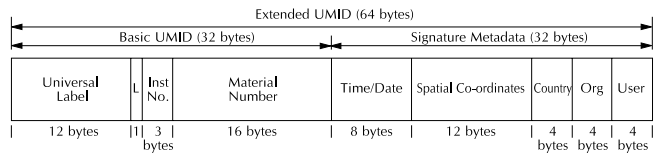

OPTIONAL ACCESSORIES

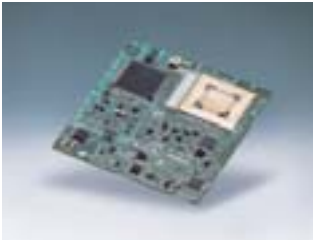

CBK-SD01
SDI Output Board

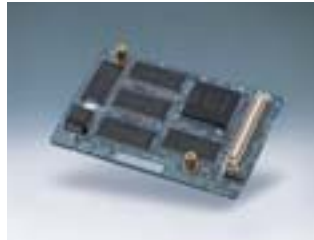

CBK-MB01
Picture Cache Board

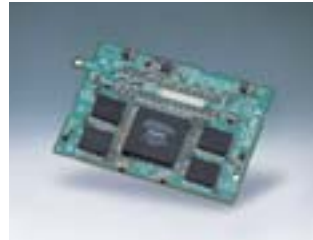

CBK-FC01
Pull-down (24P shooting) Board
(for DVW-970 only)



BKW-401
Viewfinder Rotation Bracket



RM-B150
Remote Control Unit



RM-B750
Remote Control Unit



AC-DN10
AC Adaptor



AC-DN2B
AC Adaptor



BP-GL65/GL95
Lithium-Ion Battery



BC-L70
Battery Charger



BC-M150
Battery Charger



VCT-14
Tripod Adaptor



BCT-D6/D12/D22/D32/D40
Digital Betacam S Cassettes



MSH-32/64/128
Memory Stick media



WRR-855A/855B
Wireless Microphone Receiver



WRR-862A/862B
Dual Diversity Microphone Receiver
(Adaptor required)



ECM-670/672/678
Shotgun-type Electret Condenser
Microphone



WLL-CA50
Wireless Camera Transmitter

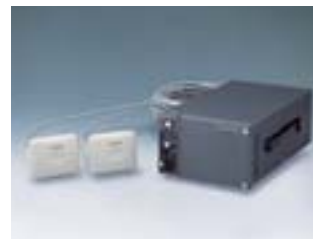

WLL-RX55
Wireless Camera Receiver

1-547-341-12, Fog-proof Filter
A-8262-537-A, Viewfinder Eye-piece (high magnification)
A-8262-538-A, Viewfinder Eye-piece (low magnification)
A-8267-737-A, Viewfinder Eye-piece (standard magnification
with special compensation for aberrations)

A-8314-798-A, Viewfinder Eye-piece (high performance, x3)
X-3608-271-1, Standard Viewfinder Lens
A-8278-057-A, Mounting Bracket for WRR-862A/862B

SYSTEM CONFIGURATIONS

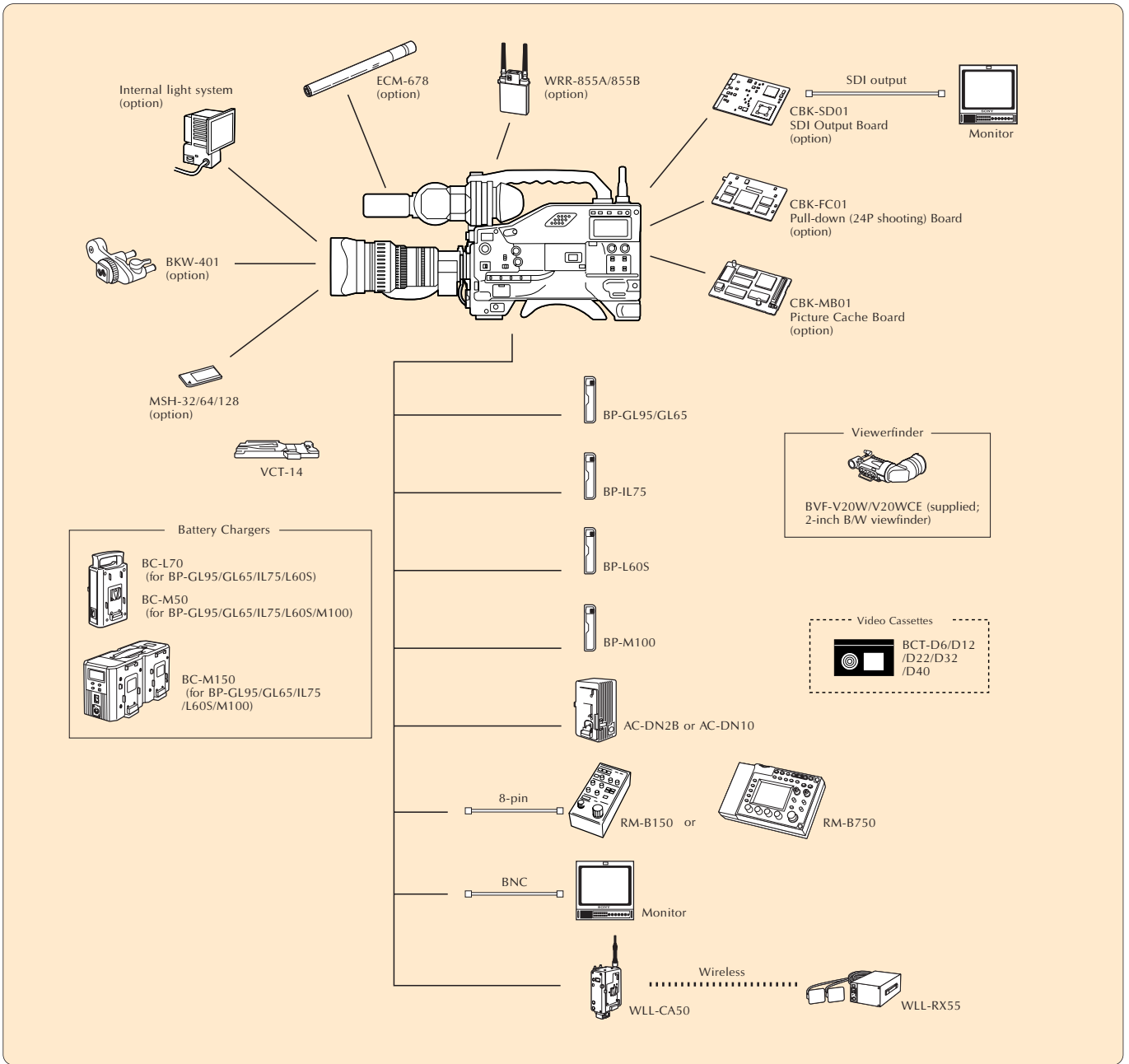

DIMENSIONS

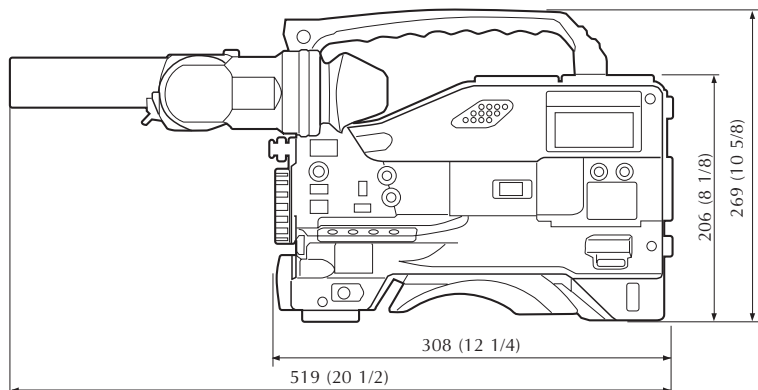
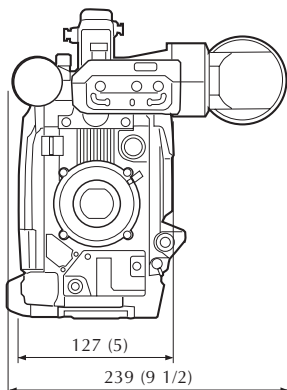

Unit:mm (inches)

SPECIFICATIONS

		DVW-970	DVW-970P
General			
Power requirements	DC 12 V +5.0 V/-1.0 V		
Power consumption	29 W (with DC 12 V power supply, REC mode, with viewfinder)		
Operating temperature	0 to +40 °C (+32 to +104 °F)		
Storage temperature	-20 to +60 °C (-4 to +140 °F)		
Operating humidity	25 to 85% (relative humidity)		
Mass	Approx. 3.7 kg (8 lb 3 oz)		
Continuous operating time	Approx. 170 min. with BP-GL95 battery at 25 °C (77 °F), REC mode		
Signal inputs/outputs			
Genlock video input	BNC type (1), 1.0 Vp-p, 75 Ω		
Audio input (CH-1/2)	XLR-3-31 type (2), -60/-50/-40/+4 dBu* selectable, high impedance, balanced		
Microphone input	XLR-3-31 type (1), -60/-50/-40 dBu*		
Time code input	BNC type (1), 0.5 to 18 Vp-p, 10 kΩ		
Analog composite output	BNC type (1), 1.0 Vp-p, 75 Ω		
SDI output	BNC type (1), 0.8 Vp-p, 75 Ω (an optional CBK-SD01 is required)		
Video test output	BNC type (1), 1.0 Vp-p, 75 Ω		
Audio output (CH-1/2)	XLR-5-pin, male (stereo)		
Time code output	BNC type (1), 1.0 Vp-p, 75 Ω		
Earphone output	Mini-jack (2)		
	* 0 dBu=0.775 Vrms.		
Other inputs/outputs			
Lens	12-pin		
VF	20-pin		
Remote	8-pin		
Wireless microphone	D-Sub 15-pin		
Light	2-pin, DC 12 V, max. 50 W		
DC input	XLR-4-pin, male, DC 11 to 17 V		
DC output	4-pin (for wireless microphone receiver), DC 12 V (max. 0.1 A)		
Battery terminal	5-pin		
Camcorder adaptor	40-pin		
Camera section			
Pickup device	Pickup device	3-chip 2/3-inch type Power HAD EX CCD	
	Aspect ratio	16:9/4:3 switchable	
	Total picture elements (H x V)	1038 x 1008	1038 x 1188
	Effective picture elements (H x V)	980 x 988	980 x 1164
Optical system	Spectral system	F1.4 prism (with quartz filter)	
	Built-in filters	1: Clear, 2: 1/4ND, 3: 1/16ND, 4: 1/64ND, A: CROSS, B: 3200K, C: 4300K, D: 6300K	
	Lens mount	2/3-inch type Sony bayonet mount	
Electrical characteristics	Scan format	525/59.94i, 525/29.97p, 525/23.976p	625/50i, 625/25p
	A/D conversion	14 bits	
	Sensitivity	F11 (typical) (2000 lx, 89.9% reflectance)	
	Minimum illumination	0.008 lx (F1.4 lens, +48 dB gain, with slow shutter mode at 16-frame accumulation)	
	Smear level	-145 dB (typical)	
	Video S/N ratio	65 dB (typical)	63 dB (typical)
	Vertical resolution	450 TV lines (with EVS) and 400 TV lines (without EVS) at 525/59.94i mode 485 TV lines at 525/29.97p and 525/23.976p modes	480 TV lines (with EVS) and 530 TV lines (without EVS) at 625/50i mode 575 TV lines at 625/25p mode
	Shutter speed	1/100, 1/125, 1/250, 1/500, 1/1000, 1/2000 s at 525/59.94i mode 1/40, 1/60, 1/120, 1/125, 1/250, 1/500, 1/1000, 1/2000 s at 525/29.97p mode 1/32, 1/48, 1/96, 1/125, 1/250, 1/500, 1/1000, 1/2000 s at 525/23.976p mode	1/60, 1/125, 1/250, 1/500, 1/1000, 1/2000 s at 625/50i mode 1/33, 1/50, 1/100, 1/125, 1/250, 1/500, 1/1000, 1/2000 s at 625/25p mode
	ECS	60 to 6000 Hz at 525/59.94i mode 30 to 7000 Hz at 525/29.97p mode 24 to 5000 Hz at 525/23.976p mode	50 to 6000 Hz at 625/50i mode 25 to 6000 Hz at 625/25p mode
	Slow shutter	1/30, 1/15, 1/10, 1/7.5, 1/6, 1/4.3, 1/3.8, 1/1.9 s (1 to 8, 16 frames)	1/25, 1/12.5, 1/8.3, 1/6.3, 1/5, 1/4.2, 1/3.6, 1/3.1, 1/1.6 s (1 to 8, 16 frames)
	Gain selection	-3, 0, 3, 6, 9, 12, 18, 24, 30, 36, 42, 48 dB (for GAIN LOW, GAIN MID, GAIN HIGH and GAIN TURBO positions)	
	Registration	0.05% (all zones, without lens)	
	Warm-up time	2 s	
	Modulation depth at 5 MHz	70% (16:9 typical)/55% (4:3 typical)	
VTR section			
Recording format	Video	Digital Betacam	
	Audio	4 ch/20 bits/48 kHz	
Tape speed	96.7 mm/s		
Record/playback time	Max. 40 min (with the BCT-D40 cassette)		
Fast forward time	Approx. 5 min (with the BCT-D40 cassette)		
Rewind time	Approx. 5 min (with the BCT-D40 cassette)		
Recommended recording media	Sony Digital Betacam S cassette: BCT-D6/D12/D22/D32/D40		
Sampling frequency	Y: 13.5 MHz, R-Y/B-Y: 6.75 MHz		
Quantization	10 bits/sample		
Digital video performance			
K-factor (2T pulse)	Less than 1%		
Y/C delay	Less than 15 ns		
Digital audio performance			
Frequency response	20 Hz to 20 kHz, +0.5/-0.8 dB		
Dynamic range	More than 85 dB (emphasis on)		
Distortion (at 1 kHz, emphasis ON, reference level)	Less than 0.08%		
Cross talk (at 1 kHz, reference level)	Less than -70 dB		
Wow & flutter	Below measurable limit		
Headroom	20 dB (ex-factory setting)		
	* The specifications given above were measured via CBK-SD01 SDI Output Board.		
Viewfinder			
CRT	2.0-inch type monochrome		
Controls	BRIGHT, CONTRAST, PEAKING controls, TALLY, ZEBRA, DISPLAY switches		
Horizontal resolution	450 TV lines (16:9)/600 TV lines (4:3)		
Microphone	Electret condenser microphone (Ultra-directional) (detachable)		
Supplied accessories			
	Operation manual (1), viewfinder (1), lens cap (1), shoulder belt (1), monaural microphone (1)		

SONY

© 2005 Sony Corporation. All rights reserved.
Reproduction in whole or in part without written permission is prohibited.
Designs, features, and specifications are subject to change without notice.
All non-metric weights and measures are approximate.
Some images in this brochure are simulated.
Sony, Digital Betacam, Power HAD, Memory Stick, TruEye, and Essence Mark are trademarks of Sony Corporation.

Distributed by